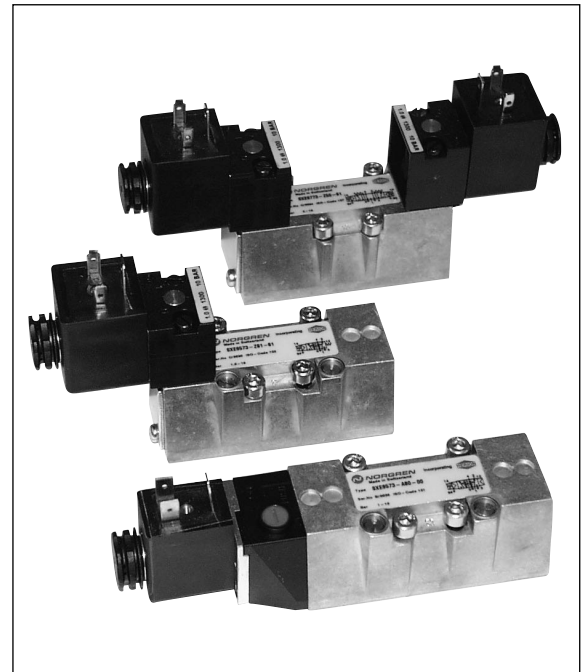

**5/2 and 5/3 Glandless Valves  
Solenoid and Pilot Actuated  
Sub-base Mounted  
ISO 5599-1 #1, #2, #3**

- **Non corrosive spool and sleeve for long trouble free life**
- **Integral flow regulators for cylinder speed control on ISO #1 and #2 models**
- **End and CNOMO solenoid pilots, 10 bar and 16 bar models with locking or non-locking manual override**
- **Wide range of sub-bases and accessories**

**Technical Data**
**Medium:**

Compressed air, 40µm filtered, lubricated or non-lubricated

**Operation:**

Glandless spool valve, solenoid pilot or air pilot actuated

**Mounting:**

On sub-bases

**Sizes:**

ISO #1, #2 and #3

**Operating Pressure (maximum pressure):**

10 bar (145 psig) solenoid pilot actuated valves

16 bar (232 psig) solenoid pilot actuated valves

16 bar (232 psig) air pilot actuated valves

Details of minimum and maximum pilot pressure see overleaf

**Flow Characteristics (unregulated):**

Size	Function	'C'	'b'	'A'	l/min	Cv	Kv
ISO #1	5/2	5,50	0,06	19,70	1230	1,20	1,08
ISO #1	5/3 APB	5,70	0,14	21,14	1320	1,35	1,15
ISO #2	5/2	10,70	0,12	39,20	2450	2,45	2,16
ISO #2	5/3 APB	10,72	0,16	40,40	2520	2,57	2,20
ISO #3	5/2	19,00	0,14	70,45	4400	4,48	3,84
ISO #3	5/3 APB	19,84	0,16	74,54	4650	4,74	4,06

**Ambient Temperature:**

-15°C\* to +50°C (5°F\* to +122°F) solenoid pilot actuated valves

-15°C\* to +80°C (5°F\* to +176°F) air pilot actuated valves

\*Consult our Technical Service for use below +2°C (36°F)

**Materials:**

Die cast aluminium body. Hard anodised, Teflon coated, matched aluminium spool and sleeve. Viton and nitrile rubber static seals. Zinc die cast locking plate. POM plastic parts. Zinc plated screws. Brass flow regulators.

**For technical data on ISO 5599-1 sub-bases and accessories see sections 5.4.187 and 5.4.188**

**Ordering Information**

To order select model number, add manual override and voltage code from page 5.4.185.04 e.g. SXE 0573-A60-00/13J

for a 5/2 double end solenoid pilot ISO #1 valve with internal pilot air supply, integral flow regulators, shrouded push button lockable manual override, 22 mm coil 24 V DC with Industrial Standard connector interface.

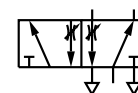

5/2

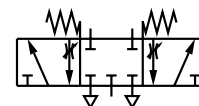
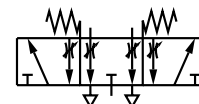
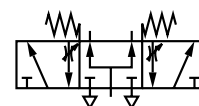
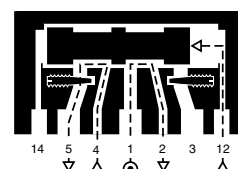
 5/3  
All ports blocked  
mid position

 5/3  
Centre open exhaust  
mid position

 5/3  
Centre open pressure  
mid position



**General Information**

**5/2 End Solenoid Pilot Actuated Valves – 10 bar models**

Symbol	Model	ISO Size	Flow Regulator	Pilot Supply	Operator 14	Return 12	Operating Pressure bar (psig)	Pilot Pressure bar (psig)	Weight kg (lb.)
	SXE9573-A70-0x/****	#1	-	Internal	Solenoid	Air Spring	1 - 10 (14.5 - 145)	-	0.33 (0.74)
	SXE9574-A70-0x/****	#2	-						0.59 (1.34)
	SXE9575-A70-0x/****	#3	-						0.85 (1.93)
	SXE9573-A80-0x/****	#1	Integral						0.33 (0.74)
	SXE9574-A80-0x/****	#2	Integral						0.59 (1.34)
	SXE9573-A75-0x/****	#1	-	External	Solenoid	Air Spring	-0.9 - 16 (-13.1 - 232)	1 - 10 (14.5 - 145)	0.33 (0.74)
	SXE9574-A75-0x/****	#2	-						0.59 (1.34)
	SXE9575-A75-0x/****	#3	-						0.85 (1.93)
	SXE9573-A85-0x/****	#1	Integral						0.33 (0.74)
	SXE9574-A85-0x/****	#2	Integral						0.59 (1.34)
	SXE9573-A71-0x/****	#1	-	Internal	Solenoid	Spring	1.8 - 10 (26.1 - 145)	-	0.33 (0.74)
	SXE9574-A71-0x/****	#2	-						0.59 (1.34)
	SXE9575-A71-0x/****	#3	-						0.85 (1.93)
	SXE9573-A81-0x/****	#1	Integral						0.33 (0.74)
	SXE9574-A81-0x/****	#2	Integral						0.59 (1.34)
	SXE9573-A76-0x/****	#1	-	External	Solenoid	Spring	-0.9 - 16 (-13.1 - 232)	1.8 - 10 (26.1 - 145)	0.33 (0.74)
	SXE9574-A76-0x/****	#2	-						0.59 (1.34)
	SXE9575-A76-0x/****	#3	-						0.85 (1.93)
	SXE9573-A86-0x/****	#1	Integral						0.33 (0.74)
	SXE9574-A86-0x/****	#2	Integral						0.59 (1.34)
	SXE0573-A50-0x/****	#1	-	Internal	Solenoid	Solenoid	2 - 10 (29 - 145)	-	0.45 (1.02)
	SXE0574-A50-0x/****	#2	-						0.72 (1.63)
	SXE0575-A50-0x/****	#3	-						0.96 (2.18)
	SXE0573-A60-0x/****	#1	Integral						0.45 (1.02)
	SXE0574-A60-0x/****	#2	Integral						0.72 (1.63)
	SXE0573-A55-0x/****	#1	-	External	Solenoid	Solenoid	-0.9 - 16 (-13.1 - 232)	2 - 10 (29 - 145)	0.45 (1.02)
	SXE0574-A55-0x/****	#2	-						0.72 (1.63)
	SXE0575-A55-0x/****	#3	-						0.96 (2.18)
	SXE0573-A65-0x/****	#1	Integral						0.45 (1.02)
	SXE0574-A65-0x/****	#2	Integral						0.72 (1.63)

**5/3 End Solenoid Pilot Actuated Valves – 10 bar models**

Symbol	Model	ISO Size	Flow Regulator	Valve Function	Pilot Supply	Operator 14	Return 12	Operating Pressure bar (psig)	Pilot Pressure bar (psig)	Weight kg (lb.)
	SXE9673-A50-0x/****	#1	-	APB	Internal	Solenoid	Solenoid	2 - 10 (29 - 145)	-	0.45 (1.02)
	SXE9674-A50-0x/****	#2	-							0.72 (1.63)
	SXE9675-A50-0x/****	#3	-							0.96 (2.18)
	SXE9673-A60-0x/****	#1	Integral							0.45 (1.02)
	SXE9674-A60-0x/****	#2	Integral							0.72 (1.63)
	SXE9673-A55-0x/****	#1	-	APB	External	Solenoid	Solenoid	-0.9 - 16 (-13.1 - 232)	2 - 10 (29 - 145)	0.45 (1.02)
	SXE9674-A55-0x/****	#2	-							0.72 (1.63)
	SXE9675-A55-0x/****	#3	-							0.96 (2.18)
	SXE9673-A65-0x/****	#1	Integral							0.45 (1.02)
	SXE9674-A65-0x/****	#2	Integral							0.72 (1.63)
	SXE9773-A50-0x/****	#1	-	COE	Internal	Solenoid	Solenoid	2 - 10 (29 - 145)	-	0.45 (1.02)
	SXE9774-A50-0x/****	#2	-							0.72 (1.63)
	SXE9775-A50-0x/****	#3	-							0.96 (2.18)
	SXE9773-A60-0x/****	#1	Integral							0.45 (1.02)
	SXE9774-A60-0x/****	#2	Integral							0.72 (1.63)
	SXE9773-A55-0x/****	#1	-	COE	External	Solenoid	Solenoid	-0.9 - 16 (-13.1 - 232)	2 - 10 (29 - 145)	0.45 (1.02)
	SXE9774-A55-0x/****	#2	-							0.72 (1.63)
	SXE9775-A55-0x/****	#3	-							0.96 (2.18)
	SXE9673-A65-0x/****	#1	Integral							0.45 (1.02)
	SXE9674-A65-0x/****	#2	Integral							0.72 (1.63)
	SXE9873-A50-0x/****	#1	-	COP	Internal	Solenoid	Solenoid	2 - 10 (29 - 145)	-	0.45 (1.02)
	SXE9874-A50-0x/****	#2	-							0.72 (1.63)
	SXE9875-A50-0x/****	#3	-							0.96 (2.18)
	SXE9873-A60-0x/****	#1	Integral							0.45 (1.02)
	SXE9874-A60-0x/****	#2	Integral							0.72 (1.63)
	SXE9873-A55-0x/****	#1	-	COP	External	Solenoid	Solenoid	-0.9 - 16 (-13.1 - 232)	2 - 10 (29 - 145)	0.45 (1.02)
	SXE9874-A55-0x/****	#2	-							0.72 (1.63)
	SXE9875-A55-0x/****	#3	-							0.96 (2.18)
	SXE9873-A65-0x/****	#1	Integral							0.45 (1.02)
	SXE9874-A65-0x/****	#2	Integral							0.72 (1.63)

× Insert 'Manual Override Option' from "Electrical Details for Solenoid Operators" on page 5.4.185.05

\*\*\* Insert 'Voltage Code' from table on page 5.4.185.05

Valve Function Designations: APB = All Ports Blocked / COE = Centre Open Exhaust / COP = Centre Open Pressure



### 5/2 CNOMO Solenoid Pilot Actuated Valves – 10 bar models

Symbol	Model	ISO Size	Flow Regulator	Pilot Supply	Operator	Return	Operating Pressure bar (psig)	Pilot Pressure bar (psig)	Weight kg (lb.)
	SXE9573-Z70-6x/****	#1	-	Internal	Solenoid	Air Spring	1 - 10 (14.5 - 145)	-	0.33 (0.74)
	SXE9574-Z70-6x/****	#2	-						0.59 (1.34)
	SXE9575-Z70-6x/****	#3	-						0.85 (1.93)
	SXE9573-Z80-6x/****	#1	Integral						0.33 (0.74)
	SXE9574-Z80-6x/****	#2	Integral						0.59 (1.34)
	SXE9573-Z75-6x/****	#1	-	External	Solenoid	Air Spring	-0.9 - 16 (-13.1 - 232)	1 - 10 (14.5 - 145)	0.33 (0.74)
	SXE9574-Z75-6x/****	#2	-						0.59 (1.34)
	SXE9575-Z75-6x/****	#3	-						0.85 (1.93)
	SXE9573-Z85-6x/****	#1	Integral						0.33 (0.74)
	SXE9574-Z85-6x/****	#2	Integral						0.59 (1.34)
	SXE9573-Z71-6x/****	#1	-	Internal	Solenoid	Spring	1.8 - 10 (26.1 - 145)	-	0.33 (0.74)
	SXE9574-Z71-6x/****	#2	-						0.59 (1.34)
	SXE9575-Z71-6x/****	#3	-						0.85 (1.93)
	SXE9573-Z81-6x/****	#1	Integral						0.33 (0.74)
	SXE9574-Z81-6x/****	#2	Integral						0.59 (1.34)
	SXE9573-Z76-6x/****	#1	-	External	Solenoid	Spring	-0.9 - 16 (-13.1 - 232)	1.8 - 10 (26.1 - 145)	0.33 (0.74)
	SXE9574-Z76-6x/****	#2	-						0.59 (1.34)
	SXE9575-Z76-6x/****	#3	-						0.85 (1.93)
	SXE9573-Z86-6x/****	#1	Integral						0.33 (0.74)
	SXE9574-Z86-6x/****	#2	Integral						0.59 (1.34)
	SXE0573-Z50-6x/****	#1	-	Internal	Solenoid	Solenoid	2 - 10 (29 - 145)	-	0.45 (1.02)
	SXE0574-Z50-6x/****	#2	-						0.72 (1.63)
	SXE0575-Z50-6x/****	#3	-						0.96 (2.18)
	SXE0573-Z60-6x/****	#1	Integral						0.45 (1.02)
	SXE0574-Z60-6x/****	#2	Integral						0.72 (1.63)
	SXE0573-Z55-6x/****	#1	-	External	Solenoid	Solenoid	-0.9 - 16 (-13.1 - 232)	2 - 10 (29 - 145)	0.45 (1.02)
	SXE0574-Z55-6x/****	#2	-						0.72 (1.63)
	SXE0575-Z55-6x/****	#3	-						0.96 (2.18)
	SXE0573-Z65-6x/****	#1	Integral						0.45 (1.02)
	SXE0574-Z65-6x/****	#2	Integral						0.72 (1.63)
	SXE1573-Z50-6x/****	#1	-	Internal	Solenoid (Priority)	Solenoid	2 - 10 (29 - 145)	-	0.45 (1.02)
	SXE1574-Z50-6x/****	#2	-						0.72 (1.63)
	SXE1575-Z50-6x/****	#3	-						0.96 (2.18)
	SXE1573-Z55-6x/****	#1	-	External	Solenoid (Priority)	Solenoid	-0.9 - 16 (-13.1 - 232)	2 - 10 (29 - 145)	0.45 (1.02)
	SXE1574-Z55-6x/****	#2	-						0.72 (1.63)
	SXE1575-Z55-6x/****	#3	-						0.96 (2.18)

### 5/3 CNOMO Solenoid Pilot Actuated Valves – 10 bar models

Symbol	Model	ISO Size	Flow Regulator	Valve Function	Pilot Supply	Operator	Return	Operating Pressure bar (psig)	Pilot Pressure bar (psig)	Weight kg (lb.)
	SXE9673-Z50-6x/****	#1	-	APB	Internal	Solenoid	Solenoid	2 - 10 (29 - 145)	-	0.45 (1.02)
	SXE9674-Z50-6x/****	#2	-							0.72 (1.63)
	SXE9675-Z50-6x/****	#3	-							0.96 (2.18)
	SXE9673-Z60-6x/****	#1	Integral							0.45 (1.02)
	SXE9674-Z60-6x/****	#2	Integral							0.72 (1.63)
	SXE9673-Z55-6x/****	#1	-	APB	External	Solenoid	Solenoid	-0.9 - 16 (-13.1 - 232)	2 - 10 (29 - 145)	0.45 (1.02)
	SXE9674-Z55-6x/****	#2	-							0.72 (1.63)
	SXE9675-Z55-6x/****	#3	-							0.96 (2.18)
	SXE9673-Z65-6x/****	#1	Integral							0.45 (1.02)
	SXE9674-Z65-6x/****	#2	Integral							0.72 (1.63)
	SXE9773-Z50-6x/****	#1	-	COE	Internal	Solenoid	Solenoid	2 - 10 (29 - 145)	-	0.45 (1.02)
	SXE9774-Z50-6x/****	#2	-							0.72 (1.63)
	SXE9775-Z50-6x/****	#3	-							0.96 (2.18)
	SXE9773-Z60-6x/****	#1	Integral							0.45 (1.02)
	SXE9774-Z60-6x/****	#2	Integral							0.72 (1.63)
	SXE9773-Z55-6x/****	#1	-	COE	External	Solenoid	Solenoid	-0.9 - 16 (-13.1 - 232)	2 - 10 (29 - 145)	0.45 (1.02)
	SXE9774-Z55-6x/****	#2	-							0.72 (1.63)
	SXE9775-Z55-6x/****	#3	-							0.96 (2.18)
	SXE9773-Z65-6x/****	#1	Integral							0.45 (1.02)
	SXE9774-Z65-6x/****	#2	Integral							0.72 (1.63)
	SXE9873-Z50-6x/****	#1	-	COP	Internal	Solenoid	Solenoid	2 - 10 (29 - 145)	-	0.45 (1.02)
	SXE9874-Z50-6x/****	#2	-							0.72 (1.63)
	SXE9875-Z50-6x/****	#3	-							0.96 (2.18)
	SXE9873-Z60-6x/****	#1	Integral							0.45 (1.02)
	SXE9874-Z60-6x/****	#2	Integral							0.72 (1.63)
	SXE9873-Z55-6x/****	#1	-	COP	External	Solenoid	Solenoid	-0.9 - 16 (-13.1 - 232)	2 - 10 (29 - 145)	0.45 (1.02)
	SXE9874-Z55-6x/****	#2	-							0.72 (1.63)
	SXE9875-Z55-6x/****	#3	-							0.96 (2.18)
	SXE9873-Z65-6x/****	#1	Integral							0.45 (1.02)
	SXE9874-Z65-6x/****	#2	Integral							0.72 (1.63)

× Insert 'Manual Override Option' from "Electrical Details for Solenoid Operators" on page 5.4.185.05

\*\*\* Insert 'Voltage Code' from table on page 5.4.185.05

Valve Function Designations: APB = All Ports Blocked / COE = Centre Open Exhaust / COP = Centre Open Pressure



5/2 CNOMO Solenoid Pilot Actuated Valves – 16 bar models

Symbol	Model	ISO Size	Flow Regulator	Pilot Supply	Operator 14	Return 12	Operating Pressure bar (psig)	Pilot Pressure bar (psig)	Weight kg (lb.)
	SXE9573-Z70-8x/****	#1	-	Internal	Solenoid	Air Spring	1 - 16 (14.5 - 232)	-	0.33 (0.74)
	SXE9574-Z70-8x/****	#2	-						0.59 (1.34)
	SXE9575-Z70-8x/****	#3	-						0.85 (1.93)
	SXE9573-Z80-8x/****	#1	Integral	External	Solenoid	Air Spring	-0.9 - 16 (-13.1 - 232)	1 - 16 (14.5 - 232)	0.33 (0.74)
	SXE9574-Z80-8x/****	#2	Integral						0.59 (1.34)
	SXE9575-Z80-8x/****	#3	-						0.85 (1.93)
	SXE9573-Z75-8x/****	#1	-	Internal	Solenoid	Spring	1.8 - 16 (26.1 - 232)	-	0.33 (0.74)
	SXE9574-Z75-8x/****	#2	-						0.59 (1.34)
	SXE9575-Z75-8x/****	#3	-						0.85 (1.93)
	SXE9573-Z85-8x/****	#1	Integral	External	Solenoid	Spring	-0.9 - 16 (-13.1 - 232)	1.8 - 16 (26.1 - 232)	0.33 (0.74)
	SXE9574-Z85-8x/****	#2	Integral						0.59 (1.34)
	SXE9575-Z85-8x/****	#3	-						0.85 (1.93)
	SXE9573-Z71-8x/****	#1	-	Internal	Solenoid	Spring	1.8 - 16 (26.1 - 232)	-	0.33 (0.74)
	SXE9574-Z71-8x/****	#2	-						0.59 (1.34)
	SXE9575-Z71-8x/****	#3	-						0.85 (1.93)
	SXE9573-Z81-8x/****	#1	Integral	External	Solenoid	Spring	-0.9 - 16 (-13.1 - 232)	1.8 - 16 (26.1 - 232)	0.33 (0.74)
	SXE9574-Z81-8x/****	#2	Integral						0.59 (1.34)
	SXE9575-Z81-8x/****	#3	-						0.85 (1.93)
	SXE9573-Z76-8x/****	#1	-	Internal	Solenoid	Solenoid	2 - 16 (29 - 232)	-	0.45 (1.02)
	SXE9574-Z76-8x/****	#2	-						0.72 (1.63)
	SXE9575-Z76-8x/****	#3	-						0.96 (2.18)
	SXE9573-Z86-8x/****	#1	Integral	External	Solenoid	Solenoid	-0.9 - 16 (-13.1 - 232)	2 - 16 (29 - 232)	0.45 (1.02)
	SXE9574-Z86-8x/****	#2	Integral						0.72 (1.63)
	SXE9575-Z86-8x/****	#3	-						0.96 (2.18)
	SXE0573-Z50-8x/****	#1	-	Internal	Solenoid	Solenoid	2 - 16 (29 - 232)	-	0.45 (1.02)
	SXE0574-Z50-8x/****	#2	-						0.72 (1.63)
	SXE0575-Z50-8x/****	#3	-						0.96 (2.18)
	SXE0573-Z60-8x/****	#1	Integral	External	Solenoid	Solenoid	-0.9 - 16 (-13.1 - 232)	2 - 16 (29 - 232)	0.45 (1.02)
	SXE0574-Z60-8x/****	#2	Integral						0.72 (1.63)
	SXE0575-Z60-8x/****	#3	-						0.96 (2.18)
	SXE1573-Z50-8x/****	#1	-	Internal	Solenoid (Priority)	Solenoid	2 - 16 (29 - 232)	-	0.45 (1.02)
	SXE1574-Z50-8x/****	#2	-						0.72 (1.63)
	SXE1575-Z50-8x/****	#3	-						0.96 (2.18)
	SXE1573-Z55-8x/****	#1	-	External	Solenoid (Priority)	Solenoid	-0.9 - 16 (-13.1 - 232)	2 - 16 (29 - 232)	0.45 (1.02)
	SXE1574-Z55-8x/****	#2	-						0.72 (1.63)
	SXE1575-Z55-8x/****	#3	-						0.96 (2.18)

5/3 CNOMO Solenoid Pilot Actuated Valves – 16 bar models

Symbol	Model	ISO Size	Flow Regulator	Valve Function	Pilot Supply	Operator 14	Return 12	Operating Pressure bar (psig)	Pilot Pressure bar (psig)	Weight kg (lb.)
	SXE9673-Z50-8x/****	#1	-	APB	Internal	Solenoid	Solenoid	2 - 16 (29 - 232)	-	0.45 (1.02)
	SXE9674-Z50-8x/****	#2	-							0.72 (1.63)
	SXE9675-Z50-8x/****	#3	-							0.96 (2.18)
	SXE9673-Z60-8x/****	#1	Integral	APB	External	Solenoid	-0.9 - 16 (-13.1 - 232)	2 - 16 (29 - 232)	-	0.45 (1.02)
	SXE9674-Z60-8x/****	#2	Integral							0.72 (1.63)
	SXE9675-Z60-8x/****	#3	-							0.96 (2.18)
	SXE9773-Z50-8x/****	#1	-	COE	Internal	Solenoid	Solenoid	2 - 16 (29 - 232)	-	0.45 (1.02)
	SXE9774-Z50-8x/****	#2	-							0.72 (1.63)
	SXE9775-Z50-8x/****	#3	-							0.96 (2.18)
	SXE9773-Z60-8x/****	#1	Integral	COE	External	Solenoid	-0.9 - 16 (-13.1 - 232)	2 - 16 (29 - 232)	-	0.45 (1.02)
	SXE9774-Z60-8x/****	#2	Integral							0.72 (1.63)
	SXE9775-Z60-8x/****	#3	-							0.96 (2.18)
	SXE9873-Z50-8x/****	#1	-	COP	Internal	Solenoid	Solenoid	2 - 16 (29 - 232)	-	0.45 (1.02)
	SXE9874-Z50-8x/****	#2	-							0.72 (1.63)
	SXE9875-Z50-8x/****	#3	-							0.96 (2.18)
	SXE9873-Z60-8x/****	#1	Integral	COP	External	Solenoid	-0.9 - 16 (-13.1 - 232)	2 - 16 (29 - 232)	-	0.45 (1.02)
	SXE9874-Z60-8x/****	#2	Integral							0.72 (1.63)
	SXE9875-Z60-8x/****	#3	-							0.96 (2.18)
	SXE9873-Z55-8x/****	#1	-	COP	Internal	Solenoid	Solenoid	2 - 16 (29 - 232)	-	0.45 (1.02)
	SXE9874-Z55-8x/****	#2	-							0.72 (1.63)
	SXE9875-Z55-8x/****	#3	-							0.96 (2.18)
	SXE9873-Z65-8x/****	#1	Integral	COP	External	Solenoid	-0.9 - 16 (-13.1 - 232)	2 - 16 (29 - 232)	-	0.45 (1.02)
	SXE9874-Z65-8x/****	#2	Integral							0.72 (1.63)
	SXE9875-Z65-8x/****	#3	-							0.96 (2.18)

× Insert 'Manual Override Option' from "Electrical Details for Solenoid Operators" on page 5.4.185.05

\*\*\* Insert 'Voltage Code' from table on page 5.4.185.05

Valve Function Designations: APB = All Ports Blocked / COE = Centre Open Exhaust / COP = Centre Open Pressure



### 5/2 Air Pilot Actuated Valves

Symbol	Model	ISO Size	Flow Regulator	Operator 14	Return 12	Operating Pressure bar (psig)	Pilot Pressure bar (psig)	Weight kg (lb.)
	SXP9573-170-00	#1	-	Air	Spring	-0.9 - 16 (-13.1 - 232)	1.8 - 16 (26.1 - 232)	0.21 (0.47)
	SXP9574-170-00	#2	-					0.45 (1.02)
	SXP9575-170-00	#3	-					0.72 (1.63)
	SXP9573-180-00	#1	Integral					0.21 (0.47)
	SXP9574-180-00	#2	Integral					0.45 (1.02)
	SXP0573-170-00	#1	-	Air	Air	-0.9 - 16 (-13.1 - 232)	2 - 16 (29 - 232)	0.30 (0.68)
	SXP0574-170-00	#2	-					0.50 (1.13)
	SXP0575-170-00	#3	-					0.72 (1.63)
	SXP0573-180-00	#1	Integral					0.30 (0.68)
	SXP0574-180-00	#2	Integral					0.50 (1.13)
	SXP1573-170-00	#1	-	Air (Priority)	Air	-0.9 - 16 (-13.1 - 232)	2 - 16 (29 - 232)	0.30 (0.68)
	SXP1574-170-00	#2	-					0.50 (1.13)
	SXP1575-170-00	#3	-					0.72 (1.63)

### 5/3 Air Pilot Actuated Valves

Symbol	Model	ISO Size	Flow Regulator	Valve Function	Operator 14	Return 12	Operating Pressure bar (psig)	Pilot Pressure bar (psig)	Weight kg (lb.)
	SXP9673-170-00	#1	-	APB	Air	Air	-0.9 - 16 (-13.1 - 232)	2 - 16 (29 - 232)	0.25 (0.57)
	SXP9674-170-00	#2	-						0.58 (1.32)
	SXP9675-170-00	#3	-						0.80 (1.82)
	SXP9673-180-00	#1	Integral						0.25 (0.57)
	SXP9674-180-00	#2	Integral						0.58 (1.32)
	SXP9773-170-00	#1	-	COE	Air	Air	-0.9 - 16 (-13.1 - 232)	2 - 16 (29 - 232)	0.25 (0.57)
	SXP9774-170-00	#2	-						0.58 (1.32)
	SXP9775-170-00	#3	-						0.80 (1.82)
	SXP9773-180-00	#1	Integral						0.25 (0.57)
	SXP9774-180-00	#2	Integral						0.58 (1.32)
	SXP9873-170-00	#1	-	COP	Air	Air	-0.9 - 16 (-13.1 - 232)	2 - 16 (29 - 232)	0.25 (0.57)
	SXP9874-170-00	#2	-						0.58 (1.32)
	SXP9875-170-00	#3	-						0.80 (1.82)
	SXP9873-180-00	#1	Integral						0.25 (0.57)
	SXP9874-180-00	#2	Integral						0.58 (1.32)

Valve Function Designations: APB = All Ports Blocked / COE = Centre Open Exhaust / COP = Centre Open Pressure

### Electrical Details for Solenoid Operators

Voltage Tolerance	± 10%
Rating	100% Continuous Duty
Inlet orifice	1,0 mm (End & CNOMO Solenoid Pilots)
Electrical Connection (corresponding to choosen coil)	DIN 43 650 table 'A' DIN 43 650 table 'B' Industrial Standard 22 mm width
Solenoid Coil	May be rotated at 90° intervals
Manual Override	End Solenoid models: Shrouded push button, spring return, lockable × = 0 Shrouded push button, spring return × = 1 CNOMO Solenoid models: Screwdriver, memory type × = 0 Push to operate spring return × = 1
Protection Class	IP 65 with sealed plug

For technical data on CNOMO solenoid pilot see section 5.4.020 or consult our Technical Departement

### Voltage Codes and Spare Coils for 16 bar models

Voltage	30 mm Coil with connector interface acc. to DIN 43 650 table "A"		Coil Part.-no
	Code	Power Inrush/Hold	
24 V DC.	33N	4 W	V10633-A33N
110/120 V 50/60 Hz	88N	10/8 VA	V10633-A88N
220/240 V 50/60 Hz	89N	10/8 VA	V10633-A89N

Other Voltages available on request.  
For further technical data on coils see section 5.4.023 or consult our Technical Department.  
Connector plugs to be ordered separately. For technical data see section 7.7.001.

### Voltage Codes and Spare Coils for 10 bar models (End & CNOMO Solenoid Operator)

Voltage	22 mm Coil with connector interface acc. to Industrial Standard		Coil Part.-no.	22 mm Coil with connector interface acc. to DIN 43650 table "B"		Coil Part.-no.	30 mm Coil with connector interface acc. to DIN 43650 table "A"		Coil Part.-no.
	Code	Power Inrush/Hold		Code	Power Inrush/Hold		Code	Power Inrush/Hold	
12 V d.c.	12J	2 W	QM/48/12J/21	12L	2 W	V10626-A12L	22N	1,5 W	V10633-A22N
24 V d.c.	13J	2 W	QM/48/13J/21	13L	2 W	V10626-A13L	23N	1,5 W	V10633-A23N
24 V 50/60 Hz	14J	4/2,5 VA	QM/48/14J/21	14L	4/2,5 VA	V10626-A14L	24N	3/2 VA	V10633-A24N
48 V 50/60 Hz	16J	4/2,5 VA	QM/48/16J/21	16L	4/2,5 VA	V10626-A16L	26N	3/2 VA	V10633-A26N
110/120 V 50/60 Hz	18J	4/2,5 VA	QM/48/18J/21	18L	4/2,5 VA	V10626-A18L	28N	3/2 VA	V10633-A28N
220/240 V 50/60 Hz	19J	9/5,0 VA	QM/48/19J/21	19L	9/5,0 VA	V10626-A19L	29N	3/2VA	V10633-A29N

Other Voltages available on request.  
For further technical data on coils see section 5.4.023 or consult our Technical Department.  
Connector plugs to be ordered separately. For technical data see section 7.7.001.



### Exhaust Flow Characteristics For Valves With Integral Flow Regulators

ISO #1

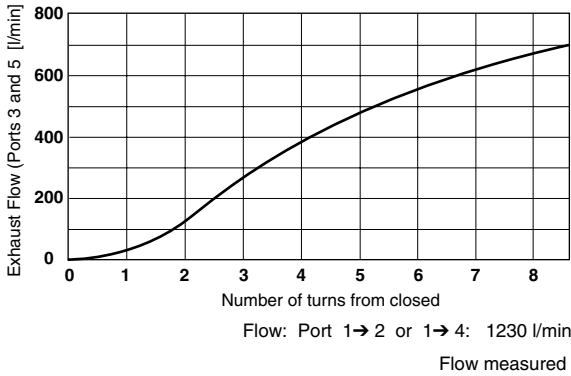

ISO #2

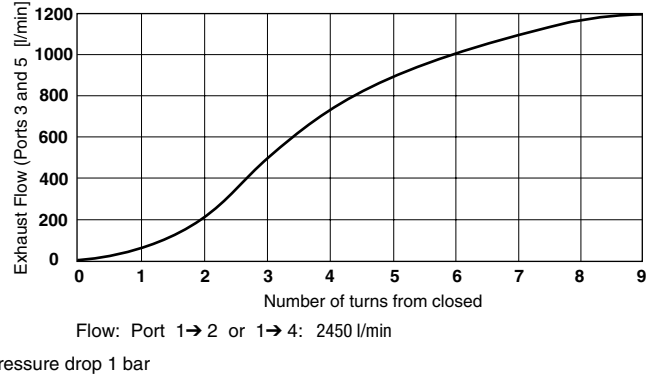

### Warning

These products are intended for use in industrial compressed air systems only. Do not use these products where pressures and temperatures can exceed those listed under 'Technical Data'.

Before using these products with fluids other than those specified, for non-industrial applications, life-support systems, or other applications not within published specifications, consult NORGREN.

Through misuse, age, or malfunction, components used in fluid power systems can fail in various modes. The system designer is warned to consider the failure modes of all component parts used in fluid power systems and to provide adequate safeguards to prevent personal injury or damage to equipment in the event of such failure.

**System designers must provide a warning to end users in the system instructional manual if protection against a failure mode cannot be adequately provided.**

System designers and end users are cautioned to review specific warnings found in instruction sheets packed and shipped with these products where applicable.

### SXE 9573-A Models Single End Solenoid Pilot Valves ISO #1

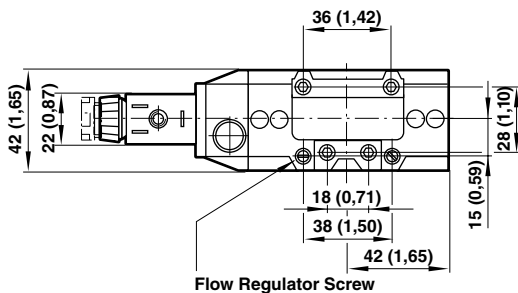
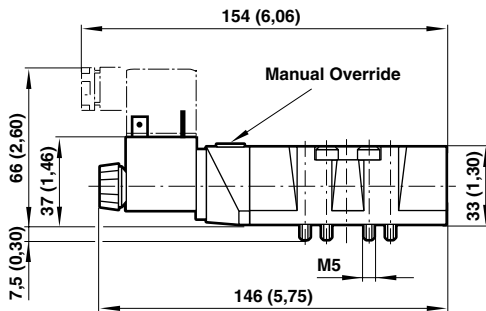

### SXE 0573-A and SXE9\*73-A Models Double End Solenoid Pilot Valves ISO #1

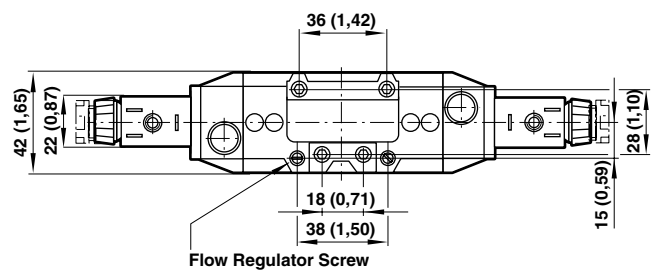
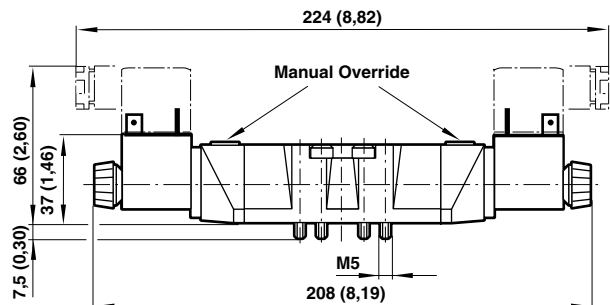

All dimensions in mm (inch)!



**SXE 9573-Z Models**  
**Single CNOMO Solenoid Pilot Valves**  
**ISO #1**

**SXE 0573-Z and SXE 9\*73-Z Models**  
**Double CNOMO Solenoid Pilot Valves**  
**ISO #1**

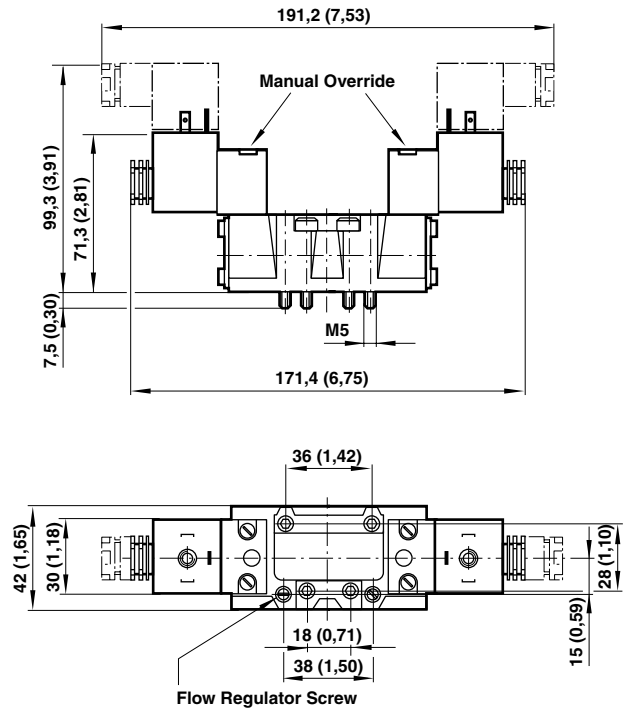
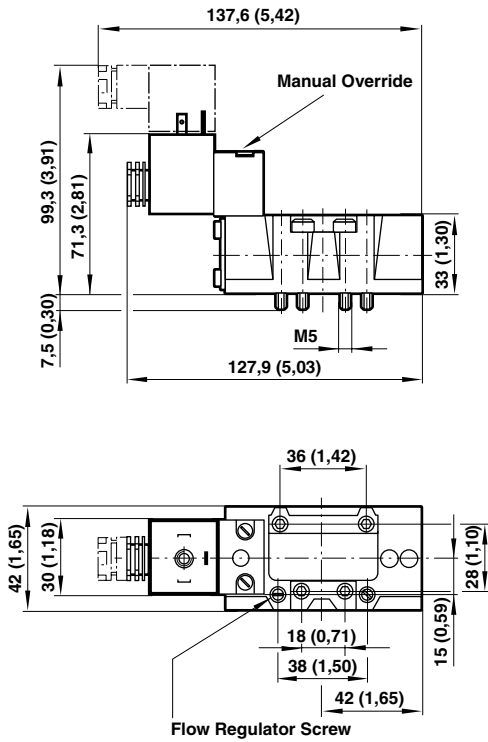

All dimensions in mm (inch)!

**SXE 9574-A Models**  
**Single End Solenoid Pilot Valves**  
**ISO #2**

**SXE 0574-A, SXE 9\*74-A Models**  
**Double End Solenoid Pilot Valves**  
**ISO #2**

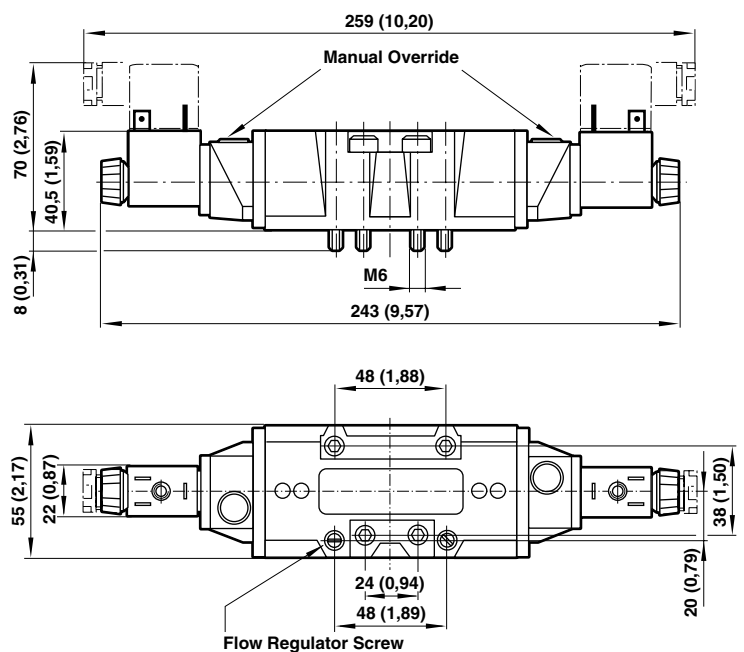
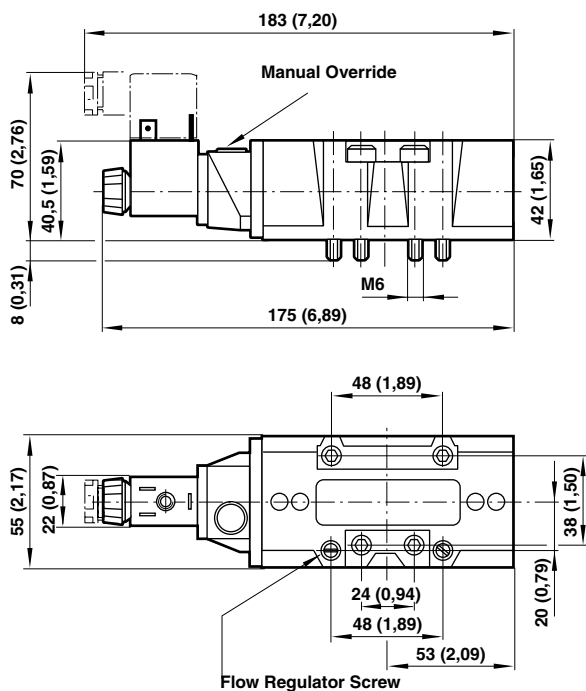

All dimensions in mm (inch)!



**SXE 9574-Z Models**  
**Single CNOMO Solenoid Pilot Valves**  
**ISO #2**

**SXE 0574-Z and SXE 9\*74-Z Models**  
**Double CNOMO Solenoid Pilot Valves**  
**ISO #2**

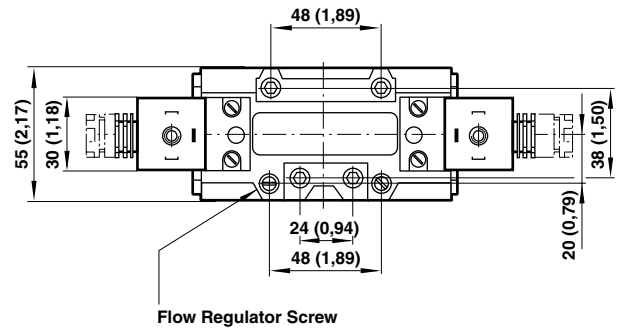
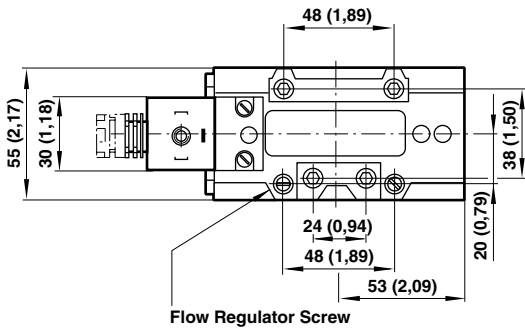
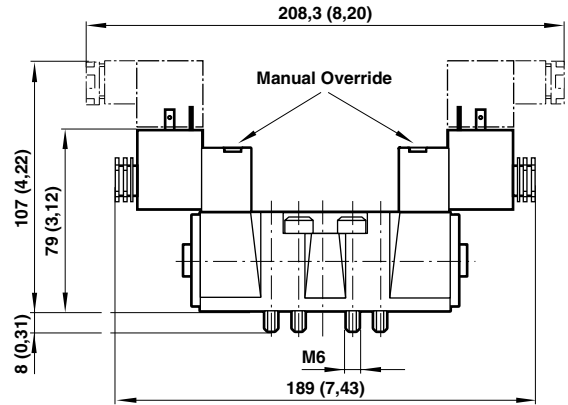
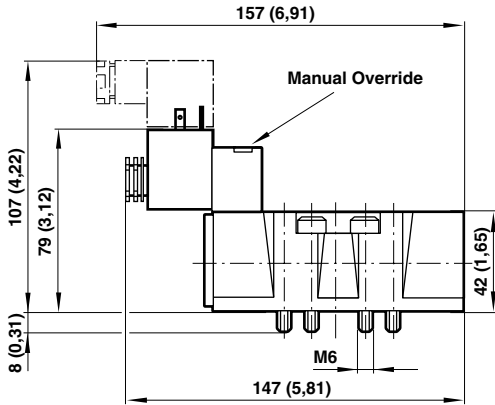

All dimensions in mm (inch)!

**SXE 9575-A Models**  
**Single End Solenoid Pilot Valves**  
**ISO #3**

**SXE 0575-A and SXE 9\*75-A Models**  
**Double End Solenoid Pilot Valves**  
**ISO #3**

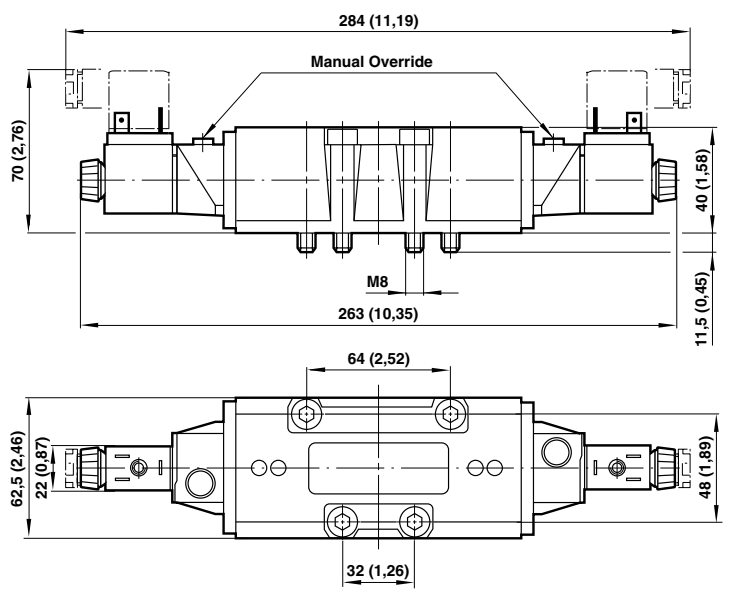
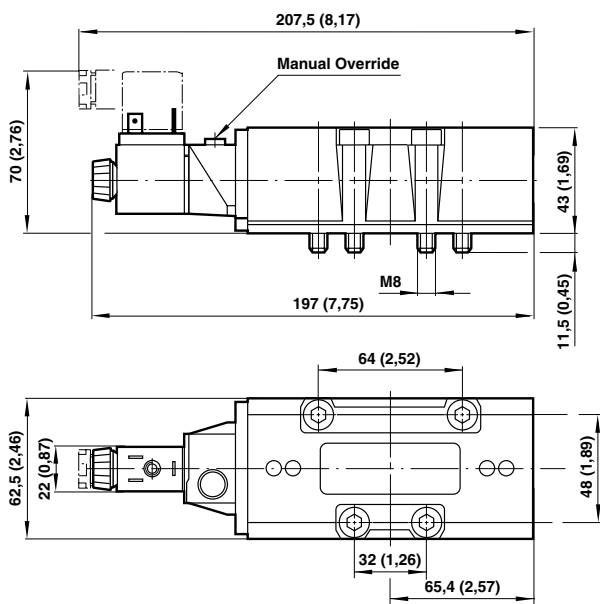

All dimensions in mm (inch)!





**SXE 9575-Z Models**  
**Single CNOMO Solenoid Pilot Valves**  
**ISO #3**

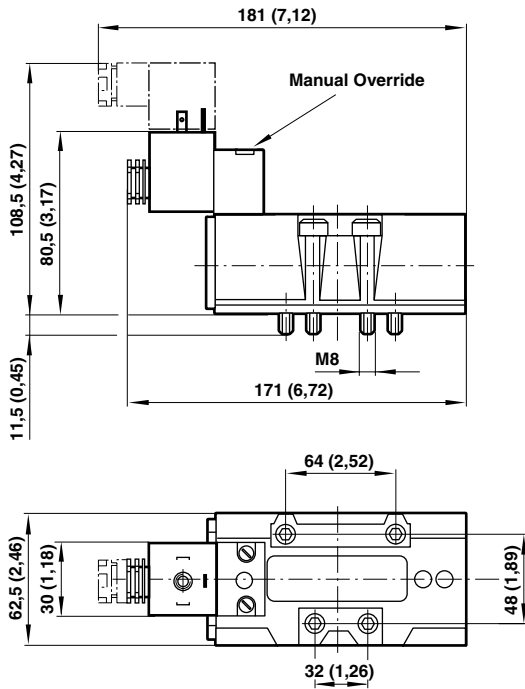

**SXE 0575-Z and SXE 9\*75-Z Models**  
**Double CNOMO Solenoid Pilot Valves**  
**ISO #3**

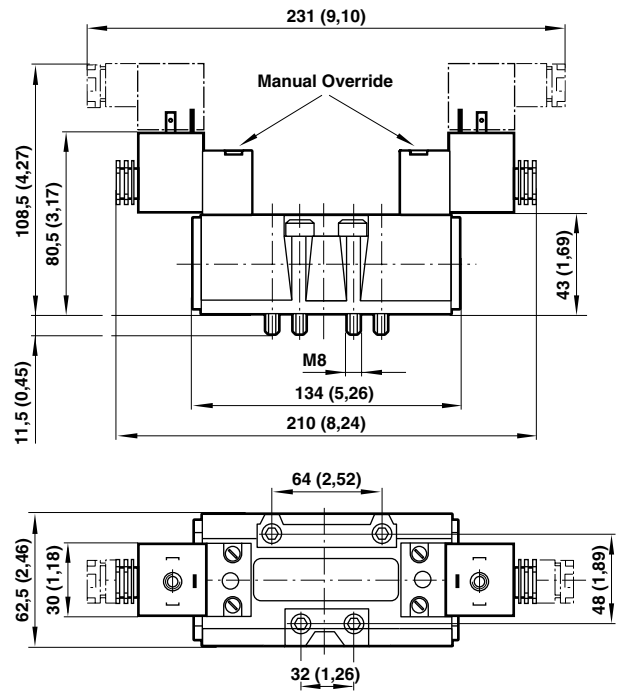

All dimensions in mm (inch)!

**SXP 9573-1 Models**  
**Single Air Pilot Valves**  
**ISO #1 (5/2)**

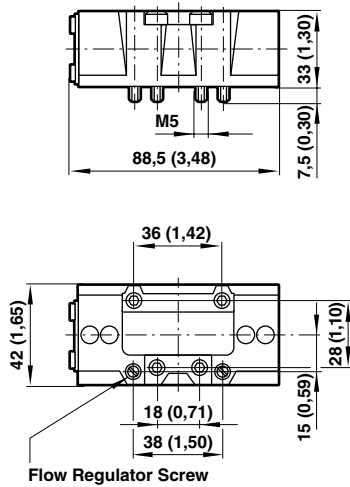

**SXP 0573-1 and SXP 9\*73-1 Models**  
**Double Air Pilot, Spring Centralised Valves**  
**ISO #1 (5/3)**

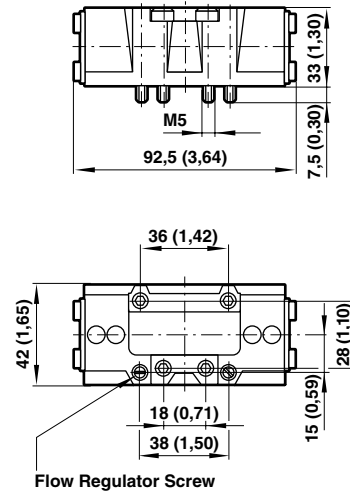

All dimensions in mm (inch)!



**SXP \*574-1 Models**  
**Single and Double Air Pilot Valves**  
**ISO #2 (5/2)**

**SXP 9\*74-1 Models**  
**Double Air Pilot, Spring Centralised Valves**  
**ISO #2 (5/3)**

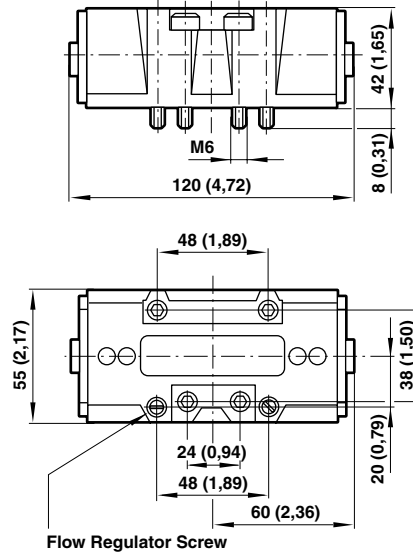
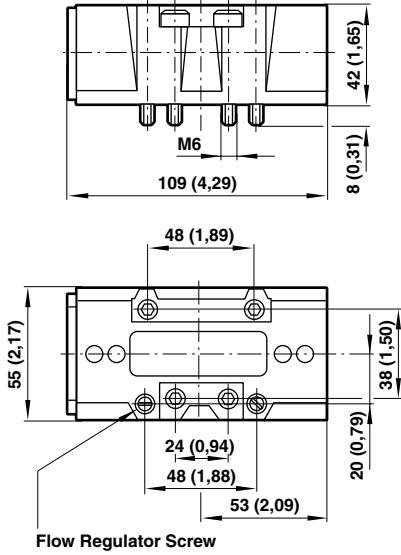

All dimensions in mm (inch)!

**SXP \*575-1 Models**  
**Single and Double Air Pilot Valves**  
**ISO #3 (5/2)**

**SXP 9\*75-1 Models**  
**Double Air Pilot, Spring Centralised Valves**  
**ISO #3 (5/3)**

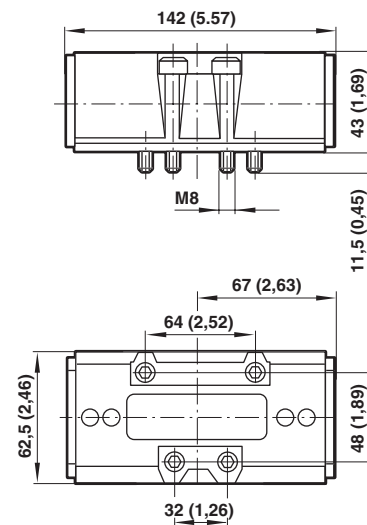
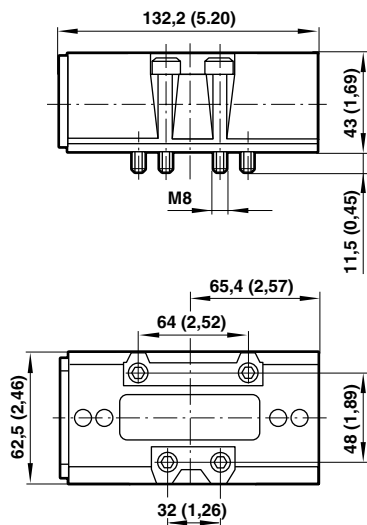

All dimensions in mm (inch)!